

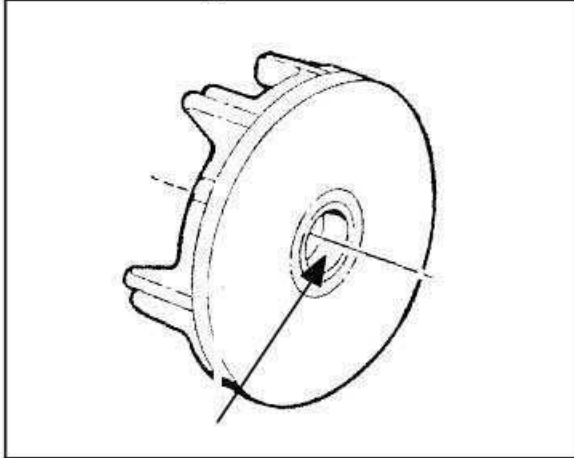

## Moveable Sheave Bushing Inspection

2. Inspect the Teflon™ coating on the moveable sheave bushing.



### Moveable Sheave Bushing Inspection:

Replace the cover bushing if more brass than Teflon™ is visible on the bushing. Refer to bushing replacement in this chapter.

## Roller, Pin and Thrust Washer Inspection

3. Inspect all rollers, bushings and roller pins by pulling a flat metal rod across the roller. Turn roller with your finger. If you notice resistance, galling, or flat spots, replace rollers, pins and thrust washers in sets of three. Also inspect to see if roller and bushing are separating. Bushing must fit tightly in roller. Use the Roller Pin Tool (PN 2870910) to replace rollers and pins. Take care not to damage roller bushing or bearing surface of the new pin during installation.

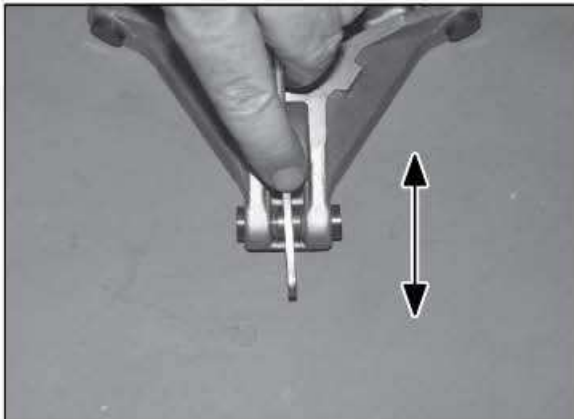

4. Rubber backed buttons can and should be used in all ATV clutches if the hollow roller pin is changed to a solid roller pin. **NOTE:** The rubber side of the

button is positioned toward the solid roller pin. It is recommended to switch all buttons to the rubber version during service (if needed).



## DRIVE CLUTCH REASSEMBLY

**NOTE:** It is important that the same number and thickness of washers are reinstalled beneath the spider during assembly. The Teflon bushings are self-lubricating. **Do not apply oil or grease to the bushings.**

1. Reassemble drive clutch in the following sequence. Be sure the "X", or the marks that were made earlier, are aligned during each phase of assembly.
  - a) "X", or the marks that were made earlier on cover
  - b) X on spider, making sure spacer washers are installed underneath spider and positioned properly in recess.
  - c) "X", or the marks that were made earlier under weight

